

# MODEL 273PL GAS PRESSURE REGULATOR

## General Description

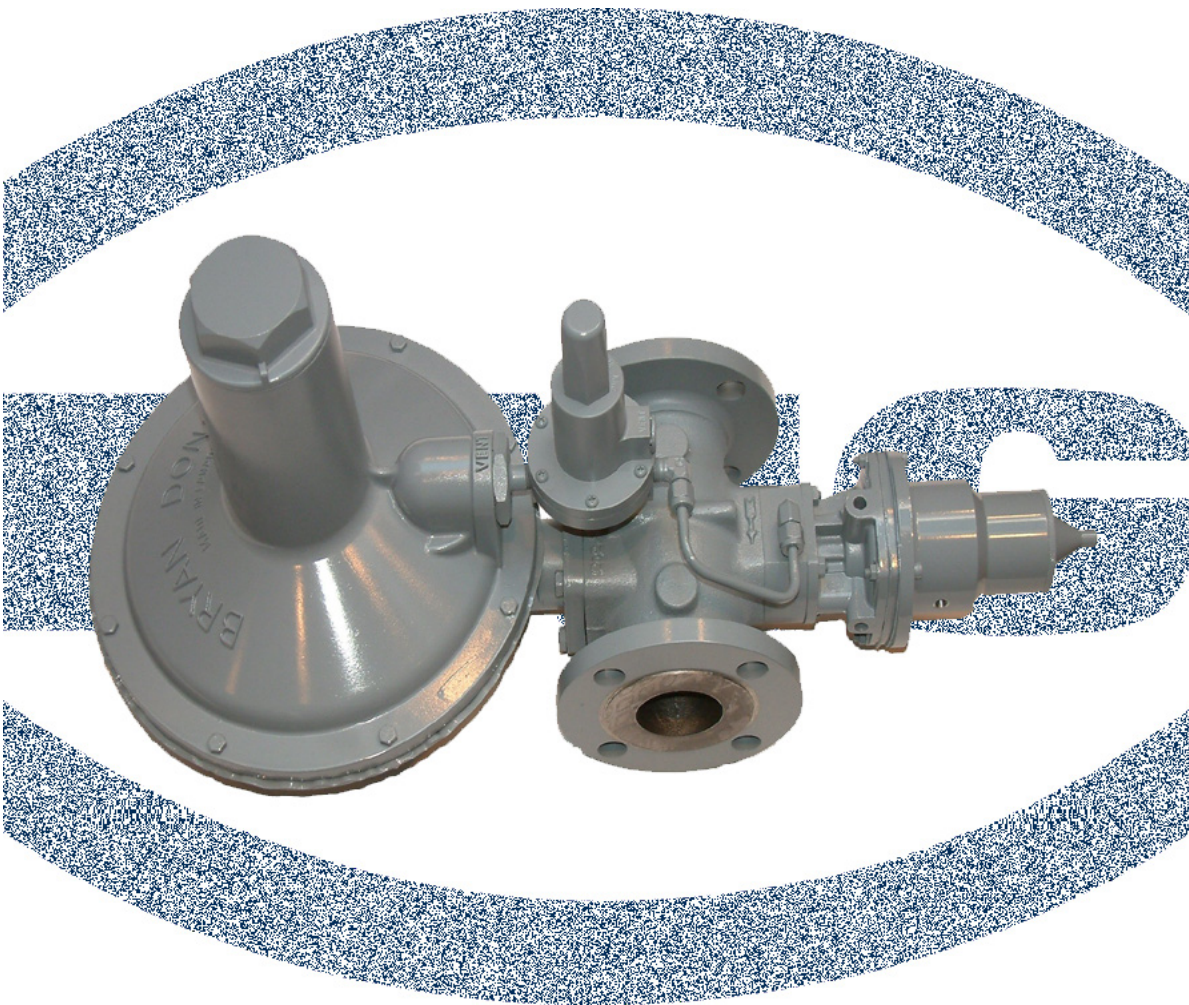

Edition  
GD273PL.06



**BRYAN DONKIN RMG CANADA LIMITED**  
Serving the Gas Industry—WORLDWIDE

# MODEL 273PL GAS PRESSURE REGULATOR



## General Description

### Applications

- Primarily utilized for commercial, industrial and multi-installation applications
- For natural gas and all non-corrosive gaseous media
- Various options for specialty applications
- Fixed Factor Billing model available for PFM applications, that ensure outlet pressure accuracy to +/- 1% absolute pressure

### Characteristics

- Specifically designed for safe, accurate, pressure reduction of gaseous media
- Wide inlet pressure range 5–280 psig (0.35-19 bar) depending on associated safety slam shut valve. If regulator has SSV than maximum inlet pressure is 150 psig (10 bar)
- Maximum inlet and operating pressure 280 psig (19 bar)
- Pilot-loaded for superior accuracy and outlet pressure control with changes in inlet pressure
- Outlet pressure settings from 2 psig to 60 psig (0.14-4 bar) over 3 pilot spring ranges
- 3 different orifices available for increased capacity performance
- 3 different inlet/outlet thread diameters (National or British Pipe Standards – NPT, BSPT, BSPP)
- Inline body (180°) design
- 2” flanged version available in ANSI150 or PN16 with flat or raised face profiles
- Available with Internal Impulse or Control Line (I.C.L.) or External Impulse or Control Line Connections (E.C.L.)
- Ease of maintenance due to interchangeable diaphragm casing cartridge
- Various safety slam-shut valve (SSV) models available for pressure/flow cut-off protection
- Custom designed and pre-fabricated regulator assemblies and pressure reducing stations available

# MODEL 273PL GAS PRESSURE REGULATOR



## General Description

◇ Outlet pressures from 2 psig to 60 psig over 3 pilot spring ranges. Set point can be adjusted easily with standard adjustable wrench.

◇ 1/4" threaded pilot regulator vent connection protected by a molded plastic fitting that is easily removed to attach vent extender or vent-line.

◇ Model 600 Pilot Regulator for superior accuracy and outlet pressure control.

◇ Reinforced diaphragm for increased speed of response and durability.

◇ Cartridge style regulator diaphragm casing design so retrofitting new regulator casings is very easy without removing regulator body from the pipe-work.

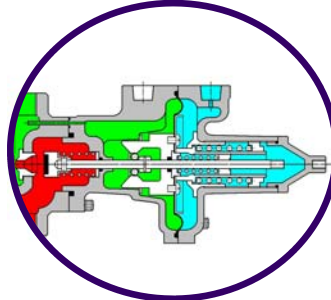

◇ Under & Over Pressure Safety Slam-Shut Valve (UPCO/OPCO) options available

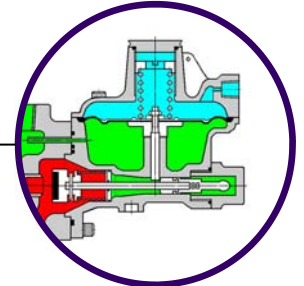

◇ Over Pressure Safety Slam-Shut Valve (OPCO) options available

◇ Integral slam-shut valves available to protect against under (UPCO) and over pressure (OPCO) conditions in the downstream pipe-work. Slam-shut valves also available with low differential pressure cut-off and thermal trip (T-type) protection feature to shut gas off if regulator is engulfed in a fire.

◇ Pressure test points available at inlet & outlet chambers of the body, as an option.

◇ Pilot regulator supply line

◇ Available with Internal Impulse or Control Line (I.C.L.) or External Impulse or Control Line Connections (E.C.L.)

◇ 3 different pipe thread diameters available on an inline (180°) body designs with 1/4", 1/2", 2" NPT, BSPT or BSPP.

◇ 2" flanged connections available in ANSI 150 or PN 16 with flat or raised face profiles

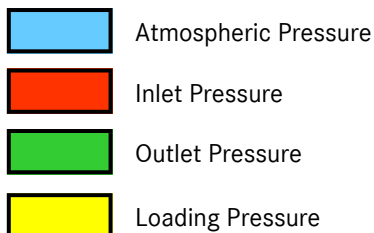

# MODEL 273PL GAS PRESSURE REGULATOR



## General Description

### Available Constructions

**273PL:** pilot operated 240 regulator

**273PL-309LP OPCO:** pilot operated 240 regulator with integral Over Pressure Cut-Off safety slam shut valve (cut off pressure up to 8 psig)

**273PL-309LP UPCO/OPCO:** pilot operated 240 regulator with integral Under and Over Pressure Cut-Off safety slam-shut valve (cut off pressure up to 8 psig)

**273PL-309LP2 OPCO:** pilot operated 240 regulator with integral Over Pressure Cut-Off safety slam-shut valve (cut off pressure up to 22 psig)

**273PL-309LP2 UPCO/OPCO:** pilot operated 240 regulator with integral Under and Over Pressure Cut-Off safety slam-shut valve (cut off pressure 22 psig)

**273PL-309LP4 OPCO:** pilot operated 240 regulator with integral Over Pressure Cut-Off safety slam-shut valve (cut off pressure up to 66 psig)

**273PL-309LP4 UPCO/OPCO:** pilot operated 240 regulator with integral Under and Over Pressure Cut-Off safety slam-shut valve (cut off pressure 66 psig)

**Thermal Protection (T-Type):** no internal relief capacity with safety diaphragms and integral safety slam-shut valve (OPCO or UPCO/OPCO) that has shut-off protection if assembly is engulfed in a fire. Assembly has many steel component parts. Only available up to cut off pressures of 12 psig.

**I.C.L. Type:** Internally sensing or internal control line to measure outlet pressure

**E.C.L. Type:** Externally sensing or external control line required to measure outlet pressure in downstream pipe-work. Diaphragm casings drilled and tapped 1/2" NPT or BSPT to connect downstream sensing line.

**F version:** complete with inlet mess filter

### Body Sizes and Connection Types

#### Inline Screwed Type Body

- 1 1/4", 1 1/2" & 2" screwed
- NPT, BSPT or BSPP threaded types

#### Flanged Type Body

- 2" flanged inlet/outlet
- ANSI150RF, ANSI150FF, PN16RF, PN16FF types

# MODEL 273PL GAS PRESSURE REGULATOR



## General Description

### Pressure Ratings

Maximum Recommended Inlet Pressure – 273PL

- 280 psig (19 bar)

Maximum Recommended Inlet Pressure – 273PL with 309LP, LP2 or LP4

- 150 psig (10 bar)

### Materials of Construction

Screwed Body	Cast Iron
Flanged Body (standard)	Cast Iron
Flanged Body (optional)	Ductile Iron, Cast Steel
Pilot Regulator Diaphragm Casings	Machined Aluminum
Pilot Supply Line	Copper
Diaphragm Casings	Die Cast Aluminum
Diaphragm	Molded Nitrile Rubber with Nylon Reinforcing
Valve Head (Seat)	Polyurethane
Diaphragm Plates	Steel
Orifice	Brass or Stainless Steel (T-type)
Fasteners	Steel
Top Cap (standard)	Aluminum

### Weights

- w/ screwed body (1¼”, 1½” & 2”) – 22 lb. (10.0 kg)
- w/ cast iron flanged body – 30 lb. (13.6 kg)
- w/ ductile iron flanged body – 32 lb. (14.5 kg)
- w/ cast steel flanged body – 38 lb. (17.3 kg)
- w/ 309 LP - add 2.2 lb. (0.9 kg)
- w/ 309 LP2 – add 2.5 lb. (1.0 kg)
- w/ 309 LP4 – add 8.0 lb. (3.2 kg)
- w/ 309 T-Type – add 5.0 lb. (2.0 kg)

### Temperature Rating

- -40° to 60° Celsius
- -40° to 120° Fahrenheit

# MODEL 273PL GAS PRESSURE REGULATOR



## General Description

### Outlet Pressure Range

Range (imperial)	Range (metric)	Spring Number/Colour
2 – 5 psig	0.14 – 0.35 bar	1047 (purple)
5 – 30 psig	0.35 – 2 bar	TX/002 (silver)
30 – 60 psig	2 – 4 bar	TX/003 (blue)

### Performance Capacity

	Outlet Pressure	Inlet Pressure		Orifice Size (millimeters/inches)			
		psig	bar	30.0mm		20.0mm	
Spring 1047 (range 2-5 psig) (range 0.14 – 0.35 bar)	SET POINT	10	(0.7)	11500	(325.8)	8300	(235.1)
	2 psig (0.14 bar)	15	(1)	14700	(416.4)	11500	(325.8)
		30	(2)	25700	(728.0)	20700	(586.4)
		45	(3)	32200	(912.2)	27600	(781.9)
	DROOP/ BOOST 11" w.c. 28 mbar	60	(4)	32200	(912.2)	27600	(781.9)
		90	(6)	32200	(912.2)	27600	(781.9)
		Accuracy Class	150	(10)	n/a	n/a	n/a
	20%	225	(15)	n/a	n/a	n/a	n/a
		300	(19)	n/a	n/a	n/a	n/a

	Outlet Pressure	Inlet Pressure		Orifice Size (millimeters/inches)			
		psig	bar	30.0mm		20.0mm	
Spring TX/002 (range 5-30 psig) (range 0.35 – 2 bar)	SET POINT	10	(0.7)	11800	(337.1)	5600	(158.6)
	5 psig (0.35 bar)	15	(1)	15700	(444.8)	12000	(339.9)
		30	(2)	25300	(716.7)	20700	(586.4)
		45	(3)	38600	(1093.5)	27600	(781.9)
	DROOP/ BOOST 28" w.c. 70 mbar	60	(4)	53700	(1521.2)	34500	(977.3)
		90	(6)	68900	(1951.8)	41400	(1172.8)
		Accuracy Class	150	(10)	n/a	n/a	23000
	20%	225	(15)	n/a	n/a	n/a	n/a
		300	(19)	n/a	n/a	n/a	n/a

Scfh (ft<sup>3</sup>/hr) - natural gas, 0.6 sg  
 Scmh (m<sup>3</sup>/hr) - natural gas, 0.6 sg

# MODEL 273PL GAS PRESSURE REGULATOR



## General Description

### Performance Capacity

	Outlet Pressure	Inlet Pressure		Orifice Size (millimeters/inches)			
		psig	bar	30.0mm		20.0mm	
	Spring TX/002 (range 5-30 psig) (range 0.35 – 2 bar)	SET POINT	30	(2)	32200	(912.2)	18900
15 psig (1 bar)		45	(3)	46900	(1328.6)	26200	(742.2)
DROOP/ BOOST		60	(4)	64300	(1821.5)	34500	(977.3)
3 psig. 2.10 mbar		90	(6)	84900	(2405.1)	46400	(1314.4)
Accuracy		150	(10)	110200	(3121.8)	70300	(1991.5)
Class		225	(15)	n/a	n/a	96400	(2730.9)
20%	300	(19)	n/a	n/a	96400	(2730.9)	

	Outlet Pressure	Inlet Pressure		Orifice Size (millimeters/inches)			
		psig	bar	30.0mm		20.0mm	
	Spring TX/002 (range 5-30 psig) (range 0.35 – 2 bar)	SET POINT	45	(3)	39100	(1107.7)	23000
30 psig (2 bar)		60	(4)	57400	(1626.1)	32200	(912.2)
DROOP/ BOOST		90	(6)	81700	(2314.4)	41400	(1172.8)
3 psig. 2.10 mbar		150	(10)	119400	(3382.4)	68900	(1951.8)
Accuracy		225	(15)	n/a	n/a	96400	(2730.8)
Class		300	(19)	n/a	n/a	110200	(3121.8)
20%							

	Outlet Pressure	Inlet Pressure		Orifice Size (millimeters/inches)			
		psig	bar	30.0mm		20.0mm	
	Spring TX/003 (range 30-60 psig) (range 2 – 4 bar)	SET POINT	45	(3)	n/a	n/a	n/a
45 psig (3 bar)		60	(4)	45900	(3131.8)	29900	(847.0)
DROOP/ BOOST		90	(6)	80400	(2277.6)	78100	(2212.5)
9 psig. 0.63 bar		150	(10)	114800	(3252.1)	78100	(2212.5)
Accuracy		225	(15)	n/a	n/a	110200	(3121.8)
Class		300	(19)	n/a	n/a	110200	(3121.8)
20%							

	Outlet Pressure	Inlet Pressure		Orifice Size (millimeters/inches)			
		psig	bar	30.0mm		20.0mm	
	Spring TX/003 (range 30-60 psig) (range 2 – 4 bar)	SET POINT	45	(3)	n/a	n/a	n/a
60 psig (4 bar)		60	(4)	n/a	n/a	n/a	n/a
DROOP/ BOOST		90	(6)	73500	(2082.2)	43600	(1235.1)
12 psig. 0.8 bar		150	(10)	128500	(3640.2)	75800	(2147.3)
Accuracy		225	(15)	n/a	n/a	110200	(3121.8)
Class		300	(19)	n/a	n/a	110200	(3121.8)
20%							



E.C.L.—External Control Line must be equipped

Scfh (ft<sup>3</sup>/hr) - natural gas, 0.6 sg  
Scmh (m<sup>3</sup>/hr) - natural gas, 0.6 sg

# MODEL 273PL GAS PRESSURE REGULATOR

## General Description

### Capacity Calculation or Correction Factors for Other Gases

<u>Gas Type</u>	<u>Specific Gravity</u>	<u>Correction Factor (CF)</u>
Air	1.00	0.77
Butane	2.01	0.55
Carbon Dioxide (Dry)	1.52	0.63
Carbon Monoxide (Dry)	0.97	0.79
Natural Gas	0.60	1.00
Nitrogen	0.97	0.79
Propane	1.53	0.63
Propane-Air-Mix	1.20	0.71

### Vent and Body Orientations

Orientation – Body Position Letter followed by Vent Position Number

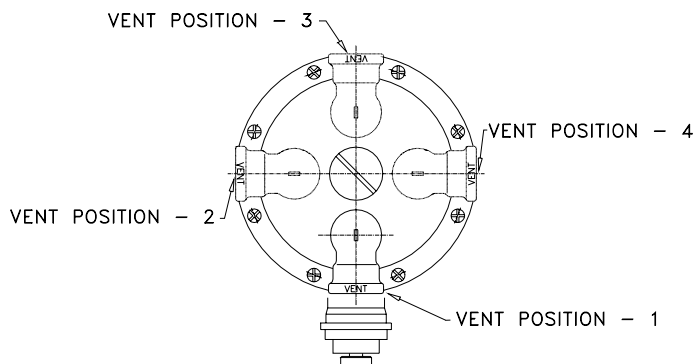

For Other Correction Factors

$$C_F = \sqrt{\frac{0.6}{\text{Sg of Gas}}}$$

Vent Direction only available in Position A

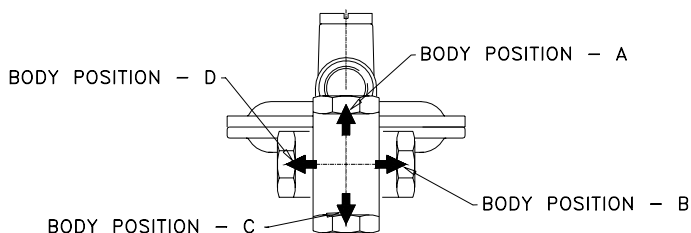

Body Direction only available in Position B & D

MATCH GAS FLOW INDICATING ARROW FOUND ON CASTING

# MODEL 273PL GAS PRESSURE REGULATOR



## General Description

### Sectional Diagrams

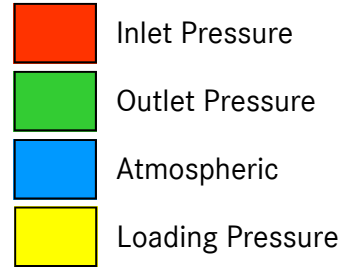

273 PL (screwed body)

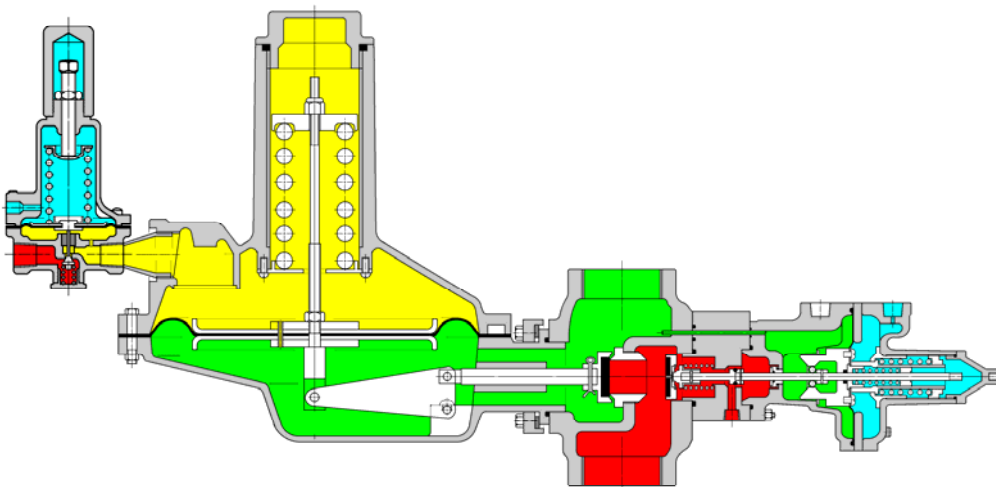
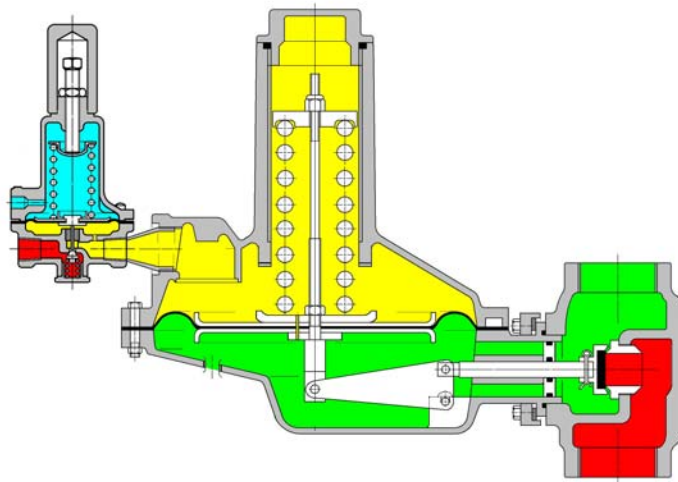

273 PL – 309LP2 UPCO/OPCO

# MODEL 273PL GAS PRESSURE REGULATOR



## General Description

## Dimensional Drawings

273PL (screwed body)

Overall Length – 18"

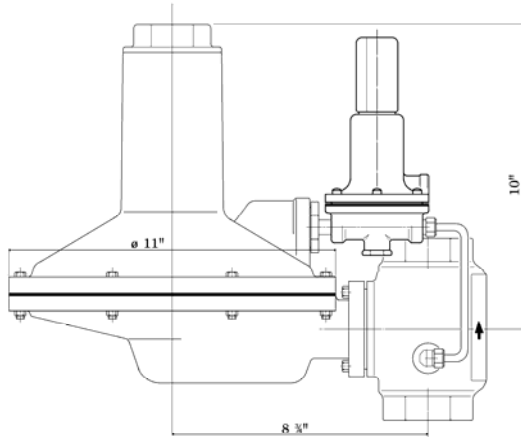

273PL (flanged body)

Overall Length – 19"

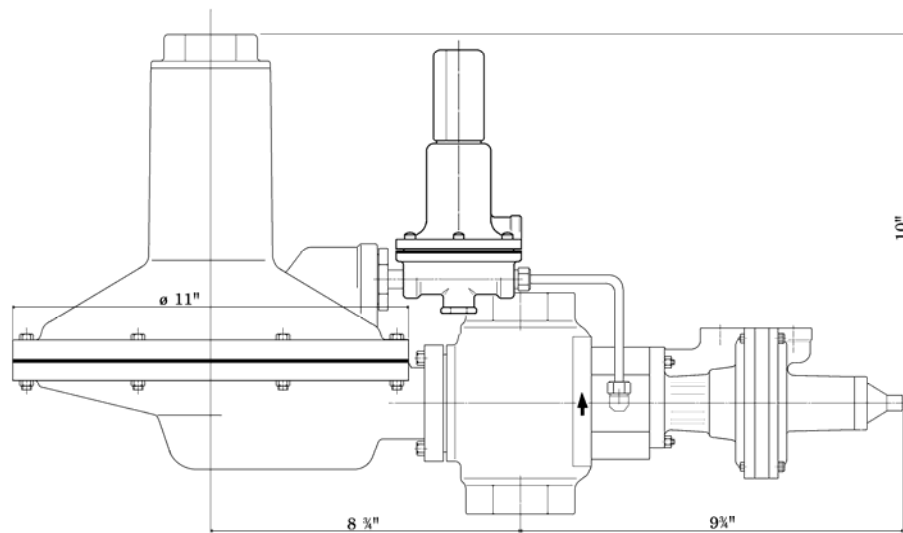
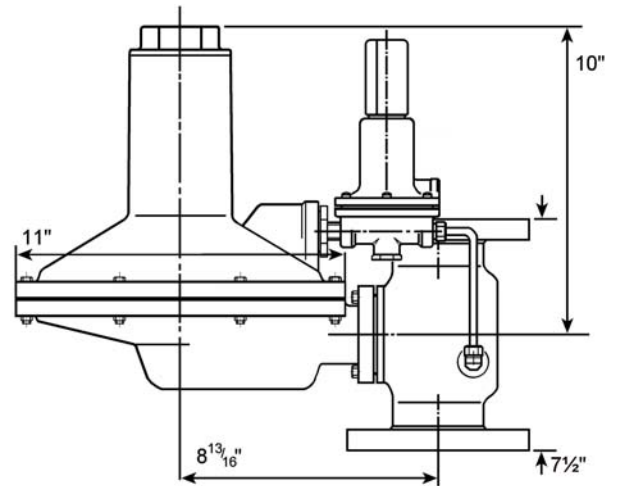

273-309LP2 (screwed body)

Overall Length – 24"

273-309LP4 (screwed body)

Overall Length – 27"

273-309LP2 (flanged body)

Overall Length – 25"

273-309LP4 (flanged body)

Overall Length – 28"

# MODEL 273PL GAS PRESSURE REGULATOR



## General Description

### Internal Relief Valve and Safety Slam Shut Valve Options

#### Regulators for Reduced Clearances or Venting Limitations

- Please contact one of our representatives for more detailed information

#### Regulators for Indoor Installations without Requirement for Vent-Line

- Please contact one of our representatives for more detailed information

### Internal Safety Relief Valve (SRV) Description

- The SRV is designed to monitor the pressure in the outlet chamber or downstream of the regulator and to relieve by either venting gas leakages or full flow capacity (depending on the device design) into the atmosphere in the event of an over-pressure condition.
- If the pressure in the measuring chamber exceeds the force of the set point spring of the relief valve, the diaphragm rises and opens the relief valve. The gas then flows from the outlet pressure line to atmosphere or another desired location.
- The relief gas pressure and flow is discharged until the pressure is returned to the predetermined safe level.
- The safety relief pressure of the internal relief valve occurs slightly above the set pressure of the main spring or outlet pressure

### Safety Slam Shut Valve (SSV) Description

- The SSV is designed to monitor the outlet pressure and to interrupt the gas flow, if preset limits are exceeded.
- This preset pressure is adjustable in the field.
- If the measured pressure reaches the set point of the SSV, a release mechanism is triggered and the SSV closes the valve on the inlet pressure side of the regulator. This closing function completely blocks the forward movement of gas past the SSV.
- Safety slam shut valves are available in over pressure cut off (OPCO) protection or under and over pressure cut off (UPCO/OPCO) protection.
- After the SSV is tripped, the condition that triggered the closing of the valve must be addressed and then the SSV can be manually reset.
- Thermal trip protection is also available as an option to shut the gas flow off, if the safety slam shut valve is exposed to high temperatures or engulfed in a fire (T-Type).
- Please contact one of our representatives for the technical brochure on all of our safety slam shut valves.

# MODEL 273PL GAS PRESSURE REGULATOR

## General Description

### External Control Line Versions (E.C.L.)

- Regulators with an external control line have the throat of the regulator blocked with a seal and the outlet pressure measuring chamber (lower diaphragm casing) drilled and tapped for an outlet pressure sensing line. It is recommended that the sensing point is a minimum of 5 times the outlet pipe diameter downstream of the regulator.
- Sensing outlet pressure via an external control line enables the regulator to respond more accurately to the downstream system.

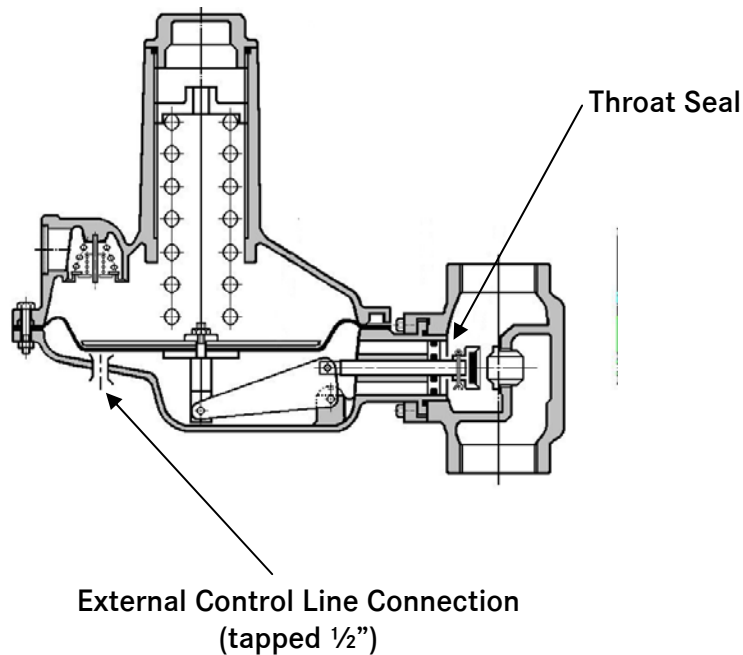

### Diagram of Regulator Station and Recommended Location of External Control Line (E.C.L.) Connections

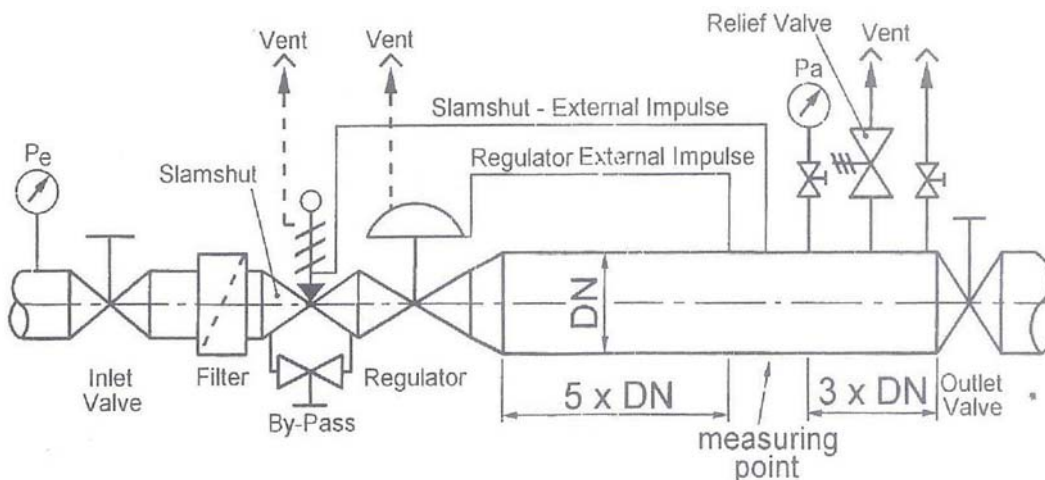

# MODEL 273PL GAS PRESSURE REGULATOR



## General Description

## Commissioning and Installation Instructions

Please contact one of our representatives for the installation and commissioning instructions. Additionally, the commissioning and installation instructions are found in each box that the equipment is shipped in and can be downloaded from the website.

## Ordering Information

1. Inlet pressure (minimum and maximum)
2. Outlet pressure requirement
3. Flow requirement (minimum and maximum)
4. Type of gas
5. Temperature
6. Pipe connections (inlet and outlet)
7. Internal or external impulse (sensing)
8. Safety options or requirements (SRV and/or SSV)
9. Vent and body orientation
10. Other critical information (system design or description)

## Product Portfolio

- Pressure regulators for every application from domestic, commercial, industrial to transmission line, city gate stations and other gas utility applications.
- Safety relief valves
- Safety slam shut valves
- Metering equipment (rotary displacement, turbine, vortex shedding, ultrasonic)
- Volume correctors (temperature and pressure)
- Filters
- Underground pressure regulator and metering modules
- Ball valves
- Station design and assembly (prefabricated stations, skid-mounted assemblies, small regulator/meter-set assemblies)
- Flame arrestors
- Data logging and software
- Check and non-return valves
- Training and after-sales service

# MODEL 273PL GAS PRESSURE REGULATOR



## General Description

## Contact Information



Bryan Donkin RMG Canada Limited  
50 Clarke Street South, Woodstock, Ontario, Canada N4S 7Y5  
Phone: +1-519-539-8531  
Fax: +1-519-537-3339  
Email: [neil@bdrmgcanada.com](mailto:neil@bdrmgcanada.com)  
Website: [www.bdrmgcanada.com](http://www.bdrmgcanada.com)



RMG Regel + Messtechnik GmbH  
Osterholzstrasse 45, D-34123, Kassel, Germany  
Phone: +49-561-5007-0  
Fax: +49-561-5007-107  
Website: [www.rmg.de](http://www.rmg.de)



Bryan Donkin RMG Gas Controls Limited  
Enterprise Drive, Holmewood, Chesterfield S42 5UZ England  
Phone: +44-1246-501501  
Fax: +44-1246-501-500  
Website: [www.bdrmg.co.uk](http://www.bdrmg.co.uk)



Bryan Donkin RMG USA Limited  
1246 Highland Avenue, Cheshire, Connecticut, U.S.A. 06410  
Phone: +1-866-469-7347  
Fax: +1-203-272-9860  
Website: [www.bryandonkinusa.com](http://www.bryandonkinusa.com)

## Distributor Information