

Gas Pressure Regulator HON 240

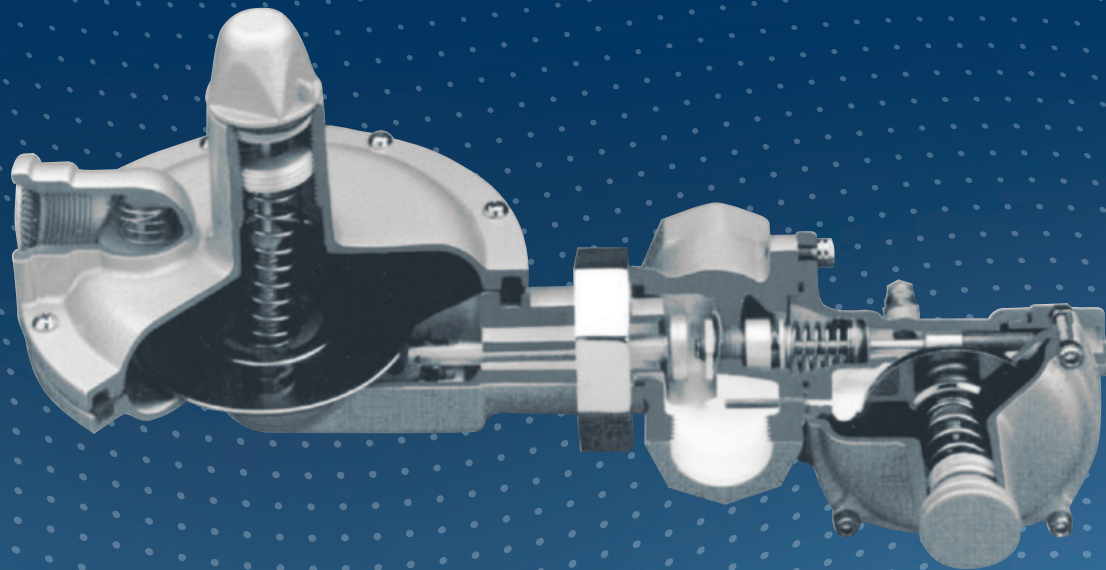

PRODUCT INFORMATION

**Serving the Gas Industry
Worldwide**

Honeywell

GAS PRESSURE REGULATOR HON 240

Introduction, Application, Features, Technical Data

Introduction

- The HON 240 is a direct acting single diaphragm, spring loaded open, lever operated regulator for use on gas pressure reduction systems.
- Control of varying inlet pressure and capacity applications is ensured by utilising a range of interchangeable orifices of varying size.
- Use with confidence on natural and manufactured gases of non-aggressive nature, including Nitrogen, Carbon Dioxide, Propane and Butane.

Application

- Designed for use on gas pressure reduction services to domestic, business premises and small industrial feeds to burners, heater units, boilers and other items of equipment where an accurate, safe and dependable pressure controlled supply is required.

Size Range

3/4" & 1" Screwed to BS.21 Rc.

Installation

The regulator may be mounted in any orientation to suit site conditions, moisture or debris must not ingress the vent hole. For optimum performance the recommended operating position is with diaphragm casing horizontal and spring housing pointing vertically upwards.

It is important when installing equipment that pipeline stresses are kept to a minimum and no undue external forces are placed on the connections.

SERVICE CONDITIONS	
Maximum Inlet Pressure (dependent upon orifice size fitted)	Up to 10.3 barg (150psig)
Outlet Pressure Range: HON 240	10 to 210 mbar (4" to 84" wg)
HON 240 PH	70 mbarg to 350 mbarg (28" to 140" wg)
Internal Relief Valve Setting	20 mbarg (8" wg) (above regulator outlet pressure set point)
Temperature Range	-20°C to +60°C

Features

- Completely independent operation of regulator and safety cut-off valve.
- Diaphragm casing can be rotated through 360° relative to regulator body and can be positioned at any angle to assist servicing and installation in confined spaces.
- Both regulator casing/valve head and safety cut-off valve can be removed from the body as cartridges, ensuring straightforward maintenance without removing the body from the pipeline.
- Wide operational pressure range
- Regulator can be fitted with Over pressure (OPCO) or Under/Over (UPCO/OPCO) pressure safety cut-off valve. These devices protect the downstream system in the event that a dangerous gas pressure condition develops.

REGULATOR RANGE					
Option	Description	240P	240LR	240R	240PH
P	No Internal Relief	•			
LR	With Limited Internal Relief		•		
R	With Internal Relief			•	
HON 309LP - OPCO	HON 309LP Over Pressure Cut-Off Valve (OPCO)	•	•	•	•
HON 309LP UPCO/OPCO	HON 309LP Combined Under/Over Pressure Safety Cut-Off Valve	•	•	•	•
PH	High outlet pressure model, no internal relief				•
K-ECL	Monitor with external control line (ECL)	•			

GAS PRESSURE REGULATOR HON 240

Spring Selection, Materials of Construction

REGULATOR SPRING RANGES (HON 240)			
Spring		Outlet Pressure Range	
Number	Colour	mbar g	ins wg
126*	Red	10 - 20	4 - 6
131*	Self	15 - 35	6 - 14
127	Green	25 - 43	10 - 17
128	Orange	38 - 67	15 - 26
392	White	40 - 75	16 - 30
393	Blue	70 - 140	28 - 56
394	Grey	140 - 210	28 - 84

REGULATOR SPRING RANGES (HON 240PH)			
Spring		Cut-Off Range	
Number	Colour	mbar g	ins wg
394	Grey	70 - 210	28 - 84
1166	Yellow	140 - 350	56 - 140

ORIFICE SELECTION	
Orifice Size	Maximum Inlet Pressure
mm	bar
2.5	10.3
3.5	8.6
5.0	6.0
6.3	6.0
7.0	3.0
9.0	2.5 / 2.0*
12.5	1.5 / 1.0*

*Use lower pressure when using spring no's 126 & 131

HON 309LP-OPCO SAFETY CUT-OFF VALVE			
Spring		Cut-Off Range	
Number	Colour	mbar g	ins wg
861	Brown	35 - 90	14 - 36
1103	Gold	80 - 130	32 - 52
1104	Purple	120 - 250	48 - 100
1105	Black	200 - 350*	80 - 140

*Maximum Over pressure set point: 260mbar (104" wg) on HON 240 regulator

HON 309LP UPCO/OPCO SAFETY CUT-OFF VALVE				
	Spring		Cut-Off Range	
	Number	Colour	mbar g	ins wg
OPCO	1109	Grey	40 - 55	16 - 22
	1110	Green	50 - 110	20 - 44
	1111	Silver	110 - 200	44 - 80
	1104	Silver/Red	150 - 240	60 - 96
UPCO	1138	Blue/Green	10 - 30	4 - 12

Minimum differential between regulator outlet and safety cut-off pressure:

- P-Type: 35 mbar (14" wg) or 10% above regulator set point, whichever is the higher
- R/LR - Type: 55 mbar (22" wg) when internal relief fitted
- When UPCO/OPCO is fitted then minimum differential for P-Type is 45 mbar (18" wg) and 65 mbar (26" wg) for R/LR-Type (with internal relief)

MATERIALS OF CONSTRUCTION	
Regulator	
Body & body cover	Ductile iron to BS EN 1563 Grade EN-GJS-400-18
Lower/Upper diaphragm casing & spring housing	Aluminium Alloy: BS.1490
Diaphragm carrier and vent plate	Nylon 11
Vent pin, spring and gauze ring	Stainless Steel: BS.970
Orifice	Brass: BS.249
Valve seat & 'O' rings	Nitrile
Diaphragm	Nitrile
Valve head, stem, spring adjuster and cap	Aluminium: BS. 1476
Lever, pins, diaphragm plate and spindle	Carbon Steel: BS.4360 (Anti-corrosion plated)
HON 309LP UPCO/OPCO Safety Cut-Off Valve	
Body	Aluminium: BS.1490 LM6
Spindle	Stainless Steel: BS.970 Grade 316 S31
Valve	Aluminium: BS.1474 Grade 6082TF
Valve Seating	Polyurethane: BS.1449 CS4
Diaphragm & 'O' rings	Nitrile
Spring Adjuster	Brass: BS.249 Grade CZ 121
Spring	Spring Carbon Steel: BS.5216 Grade HS3

GAS PRESSURE REGULATOR HON 240

Capacities in SCMh for Natural Gas (SG: 0.6)

CAPACITIES									
Spring No. and Outlet Pressure	Inlet Pressure		Orifice Size - Millimetres						
	mbar	2.5	3.5	5	6.3	7	9	12.5	
SPRING No. 126 10-20 mbar	20				2.4	2.5	2.8	4.1	
	25			1.9	2.5	2.7	3.4	4.8	
	45			2.5	3.4	4.0	4.6	6.4	
	69	1.2	2.4	3.7	5.1	5.5	6.5	8.7	
	207	1.8	4.4	6.0	6.7	8.9	11.3	21.7	
	345	3.0	5.8	8.8	12.2	14.4	17.5	31.9	
	690	6.2	9.8	15.8	22.9	24.2	35.4	51.0	
	1 bar	7.8	13.8	19.1	25.5	30.4	41.0		
	15 mbar	1.5	10.4	19.5	38.2	51.0	51.0	51.0	
		2.0	12.6	26.4	44.6	51.0	51.0	51.0	
	DROOP 2.5 mbar	2.5	15.0	31.0	46.7	51.0	51.0		
		3.0	17.0	34.7	51.0	51.0	51.0		
		4.0	20.8	37.4	51.0	51.0			
		6.0	29.7	38.3	51.0	51.0			
		7.0	35.7	40.2					
	8.0	41.0	46.0						
	8.6	46.7	46.0						
	10	46.7							
SPRING No. 131 15-35 mbar	45			2.2	2.8	3.0	4.0	5.4	
	69	1.5	2.4	3.1	4.1	5.0	5.7	8.3	
	210	2.5	4.2	6.1	6.4	9.0	10.9	17.8	
	345	4.3	6.4	8.3	11.5	14.3	16.9	26.8	
	690	6.2	8.6	15.3	21.7	22.1	31.3	48.4	
	1 bar	8.4	12.4	18.9	25.5	30.1	40.2		
	25 mbar	1.5	10.8	19.0	36.8	51.0	51.0	51.0	
	3.7 mbar								
	2 - 10 BAR CAPACITIES IDENTICAL TO THOSE FOR SPRING NO 126 GIVEN ABOVE								
SPRING No. 127 25-43 mbar	45				2.2	2.4	3.0	4.2	
	69			2.8	3.8	4.4	5.2	7.6	
	210	2.4	5.5	6.1	6.4	8.4	10.9	17.8	
	345	4.2	6.9	8.3	11.5	13.4	16.7	26.8	
	690	6.9	10.4	15.3	21.7	26.5	36.5	48.4	
	1 bar	8.4	14.6	18.9	25.5	37.1	43.8		
	37.5 mbar	1.5	10.6	20.1	36.8	51.0	51.0	51.0	
	5.6 mbar								
	2 - 10 BAR CAPACITIES IDENTICAL TO THOSE FOR SPRING NO 126 GIVEN ABOVE								
SPRING No. 392 40-75 mbar	69	1.2	1.7	2.0	3.8	4.0	5.2	6.9	
	210	2.4	3.2	3.7	6.2	6.6	9.7	15.1	
	345	3.4	4.8	5.6	10.1	12.7	14.0	22.4	
	690	6.6	8.5	9.6	15.2	17.7	24.1	41.9	
	1 bar	9.1	11.7	15.9	19.3	26.7	36.4	54.7	
	60 mbar	1.5	11.1	15.0	29.7	37.1	42.1	47.6	
		2.0	14.0	19.5	35.7	44.3	50.4	73.6	
		2.5	15.6	23.5	43.2	51.5	65.1	73.6	
	9.5 mbar	3.0	18.6	25.6	44.7	58.6	73.6		
		4.0	20.4	32.6	46.8	58.6			
		6.0	32.3	59.5	65.1	58.6			
		7.0	43.2	65.1					
		8.0	48.7	65.1					
		8.6	52.4	65.1					
		10	52.4						
SPRING No. 393 70-140 mbar	210	1.0	3.3	4.1	7.4	7.8	10.0	15.0	
	345	2.5	6.2	7.0	12.0	12.3	14.6	23.9	
	690	5.1	9.8	12.9	16.3	17.7	29.2	40.3	
	1 bar	6.6	13.3	17.3	20.3	23.2	36.2	53.8	
	105 mbar	1.5	9.1	18.3	24.9	29.4	35.0	48.5	
		2.0	10.9	22.5	34.7	40.1	40.7	60.5	
		2.5	13.2	27.4	42.9	47.4	48.8	73.6	
	16 mbar	3.0	14.9	30.6	44.7	55.2	57.2		
		4.0	18.3	37.4	44.9	55.2			
		6.0	26.5	48.0	50.4	55.2			
		7.0	34.7	52.4					
		8.0	45.3	65.1					
		8.6	45.3	65.1					
		10	45.3						
	SPRING No. 394 140-210 mbar	210	1.6	2.8	2.9	4.6	5.0	6.6	11.0
345		2.9	4.8	5.0	8.0	8.7	11.4	19.0	
690		5.0	8.9	11.9	14.1	17.4	23.4	33.6	
1 bar		7.1	10.6	14.2	16.2	20.0	29.7	45.7	
175 mbar		1.5	9.1	13.6	24.1	30.0	36.2	43.0	
		2.0	10.9	15.0	30.2	35.4	40.4	46.7	
		2.5	12.8	20.4	33.8	42.3	46.2	61.2	
26 mbar		3.0	14.7	23.5	35.1	45.4	50.8		
		4.0	18.3	31.0	38.5				
		6.0	26.5	40.0	42.1				
		7.0	32.6	45.7					
		8.0	39.5	51.7					
		8.6	40.4	52.4					
		10	40.4						

Type of Gases:
The capacities shown in the table are given in terms of natural gas SG 0.6. For all other gases multiply by the following correction factor:

$$\sqrt{\frac{0.6}{\text{SG of gas handled}}}$$

GAS PRESSURE REGULATOR HON 240

Dimensions & Weights, Sectional Arrangement

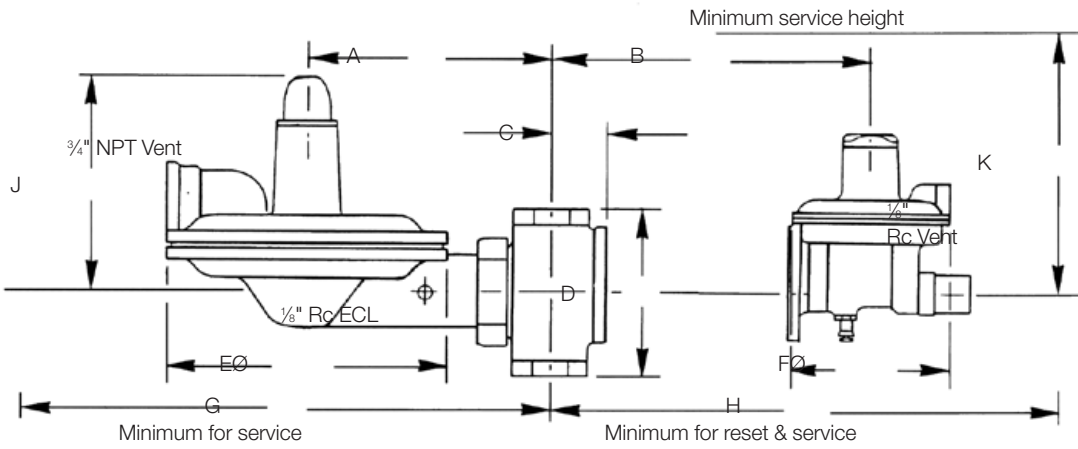

Size & Model	A	B	C	D	E	F	G	H	J	K	WT.Kg
3/4" & 1"	153	-	40	102	172	-	270	-	145	205	2.5
3/4" & 1" c/w HON 309LP OPCO	153	100	-	102	172	115	270	230	145	205	3.2
3/4" & 1" HON 240PH	153	-	41	102	172	-	270	-	165	205	3.25

Sectional Arrangement

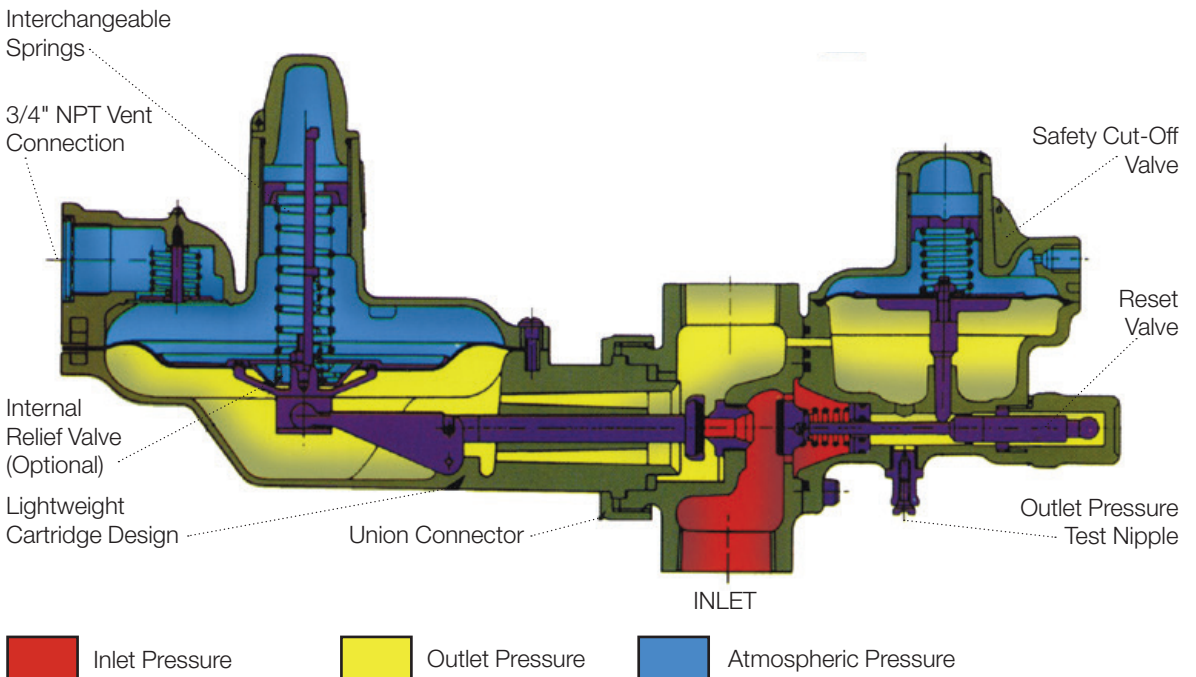

For More Information

To learn more about Honeywell's
Advanced Gas Solutions, visit
www.honeywellprocess.com or contact
your Honeywell account manager.

Honeywell Process Solutions

Honeywell Bryan Donkin Gas Technologies Ltd.

Enterprise Drive, Holmewood
Chesterfield S42 5UZ, England

Tel: +44 (0)1246 501-501

Fax: +44 (0)1246 501-500

www.honeywellprocess.com

The Honeywell logo is displayed in a bold, red, sans-serif font.

R.240
2016-03
©2016 Honeywell International Inc.